

www.costeffectiveequipment.com

+1-573-466-4300

Operations Manual

Apogee® 300 Flange Bake Plate

Models: A-F-B3-2

A-X-B3-2



Cee
Cost Effective Equipment

1	INTRODUCTION	4
1.1	CONFIDENTIALITY STATEMENT	4
1.2	WARRANTY	4
1.3	RETURNED MATERIALS	4
1.4	MODEL AND REVISIONS	4
1.5	ENVIRONMENTAL CONSIDERATIONS	5
1.6	GENERAL SAFETY HAZARDS / PRECAUTIONS	5
1.7	ELECTRICAL	6
1.8	MECHANICAL	6
1.9	THERMAL	6
1.10	CHEMICAL	6
1.11	LOCKOUT/TAGOUT PROCEDURES AND INFORMATION	7
1.12	INTENDED USE OF MACHINE	8
2	EQUIPMENT DESCRIPTION	9
2.1	USER CONTROLS	9
2.2	DIMENSIONS	10
2.3	FEATURES & PROGRAMMABILITY	11
2.4	PRECISION	11
2.5	RELIABILITY	12
2.6	NRTL	12
2.7	UTILITIES	12
3	INSTALLATION	13
3.1	MOUNTING THE FLANGE PROCESS MODULE	13
3.2	MOUNTING THE FLANGE CONTROLLER	14
3.3	FACILITIES REQUIREMENTS	15
3.4	ENVIRONMENT	15
3.5	UNPACKAGING & INSPECTION	15
3.6	SYSTEM INSTALLATION & SETUP	16
3.7	START UP	16
3.8	SYSTEM CHECKS	16
4	DATASTREAM™ TECHNOLOGY	20
4.1	SAFETY TEMPERATURE WARNING	20
4.2	TIMER CONTROLS	20
4.3	SYSTEM PARAMETERS	21
4.4	MANUAL CONTROLS – APOGEE® BAKE PLATE	21
4.5	PREPARATION	26
4.6	RUNNING RECIPES	27
4.7	EDITING RECIPES	29
4.8	TOOL SPECIFIC SETTINGS – APOGEE® BAKE PLATE	29
5	BAKE PLATE THEORY	30
5.1	BAKE PLATES VS CONVENTIONAL OVENS	30
5.2	THE SKIN EFFECT	30
5.3	HOTPLATE BAKE VARIABLES AND METHODS	31
5.4	BAKE TEMPERATURE	31
5.5	BAKE METHODS	31
5.6	BAKE TIME	32
5.7	EXHAUST COVER	32

5.8	OVEN VS BAKE PLATE EXAMPLES	32
5.9	REFLOW SOLDERING	33
5.10	BAKE PLATE PROCESS TROUBLESHOOTING.....	33
6	PREVENTATIVE MAINTENANCE	34
6.1	SERVICE AND REPAIRS	34
6.2	FAULT CONDITION	34
6.3	SAFETY CHECKS.....	34
6.4	MECHANICAL/UTILITIES CHECKLIST.....	34
6.5	CLEANING	35
7	TABLE OF REVISIONS	36

1 Introduction

1.1 Confidentiality Statement

Information supplied is for the use in the operation and/or maintenance of Cee® equipment. Neither this document nor the information it contains shall be disclosed to others for manufacturing or any other purpose without written authorization from Cost Effective Equipment, LLC.

1.2 Warranty

Cost Effective Equipment, LLC warrants to the original purchaser (Buyer) that equipment is free from defects in material and workmanship under normal use and service in accordance with Cee® instructions and specifications. Buyer shall promptly notify Cee® of any claim against this warranty, and any item to be returned to Cee® shall be sent with transportation charges prepaid by Buyer, clearly marked with a Return Authorization (RMA) number obtained from Cee® Customer Support. Cee's obligation under this warranty is limited to the repair or replacement, at Cee's option, of any equipment, component or part which is determined by Cee® to be defective in material or workmanship. This obligation shall expire one (1) year after the initial shipment of the equipment from Cee®. This warranty shall be void if:

- Any failure is due to the misuse, neglect, improper installation of, or accident to the equipment.
- Any major repairs or alterations are made to equipment by anyone other than a duly authorized representative of Cee®. Representatives of Buyer will be authorized to make repairs to the equipment without voiding warranty, on completion of the Cee® training program.
- Replacement parts are used other than those made or recommended by Cee®.

CEE® MAKES NO OTHER WARRANTIES, EXPRESSED OR IMPLIED, WITH RESPECT TO EQUIPMENT. NO WARRANTY IS MADE AS TO THE MERCHANTABILITY OF THE EQUIPMENT NOR ITS FITNESS FOR ANY PARTICULAR PURPOSE. In no event shall Cee® be liable for consequential loss or damages, however caused. No person or representative of Cee® is authorized to assume for Cee® any liability in connection with equipment nor to make any change to this warranty unless such change or modification is put in writing and approved by an authorized representative of Cee® in writing.

This warranty shall be governed by the laws of the state of Missouri, U.S.A.

1.3 Returned Materials

Any materials, parts, or equipment returned to Cost Effective Equipment, LLC must be clearly labeled with a Return Material Authorization (RMA) number.



To obtain an RMA number, contact:

Cost Effective Equipment, LLC Customer Support
Telephone +1-573-466-4300
Email..... support@costeffectiveequipment.com
Web Address..... www.costeffectiveequipment.com
Physical Address..... 6 Industrial Drive; St. James, Missouri 65559



1.4 Model and Revisions

The model and serial number information for the Cee® Apogee® 300 Flange Bake Plate are located on the rear panel. Software version information can be found on the *About* screen. Refer to the [*DataStream™ Manual*](#) for screen shots and a detailed explanation of the system software.



1.5 Environmental Considerations

	<p>Cee® fosters sustainability through innovation in the durability and reliability of our precision tools and equipment. Individual component modules are engineered for serviceability ensuring long lasting performance. Processes are designed to minimize use & consumption of chemical compounds ensuring accurate, replicable, industry-leading results every time.</p>	<p>Cee® favorise la durabilité grâce à l'innovation dans la durabilité et la fiabilité de nos outils et équipements de précision. Les modules de composants individuels sont conçus pour une facilité d'entretien garantissant des performances durables. Les processus sont conçus pour minimiser l'utilisation et la consommation de composés chimiques, garantissant à chaque fois des résultats précis, reproductibles et à la pointe de l'industrie.</p>
	<p>Cee® diligently screens suppliers to ensure conflict-free sourcing of minerals and product components are constructed of recycled materials wherever possible.</p>	<p>Cee® sélectionne avec diligence les fournisseurs pour garantir que l'approvisionnement en minéraux est sans conflit et que les composants des produits sont fabriqués à partir de matériaux recyclés dans la mesure du possible.</p>
	<p>Cee® tools and equipment operate without the use of ozone depleting substances (ODSs) including chlorofluorocarbons (CFCs), methyl chloroform, hydrochlorofluorocarbons (HCFCs), carbon tetrachloride, perfluoro compounds (PFCs), or other volatile compounds/organic solvents.</p>	<p>Les outils et équipements Cee® fonctionnent sans utilisation de substances appauvrissant la couche d'ozone (SACO), notamment les chlorofluorocarbures (CFC), le méthyle chloroforme, les hydrochlorofluorocarbures (HCFC), le tétrachlorure de carbone, les composés perfluorés (PFC) ou d'autres composés volatils/solvants organiques.</p>



1.6 General Safety Hazards / Precautions

	<p>Read this manual in its entirety before operating or servicing the machine.</p>	<p>Lisez ce manuel dans son intégralité avant d'utiliser ou d'entretenir la machine.</p>
	<p>The unit is very heavy and proper precautions should be taken when handling the machine to minimize the risk of injury. Labels are placed on the machine to identify areas where caution is needed during operation.</p>	<p>L'unité est très lourde et des précautions appropriées doivent être prises lors de la manipulation de la machine pour minimiser le risque de blessure. Des étiquettes sont placées sur la machine pour identifier les zones où des précautions sont nécessaires pendant le fonctionnement.</p>
	<p>Sound pressure measurements greater than 80dB(A) are considered hazardous. The following sound pressure measurements were obtained from the Cee® Apogee® 300 Bake Plate at a distance of 3 ft (0.9 m) from the system:</p> <p>Stand-by Mode: 40dB(A) Normal Operations: 40dB(A)</p>	<p>Les mesures de pression acoustique supérieures à 80 dB(A) sont considérées comme dangereuses. Les mesures de pression acoustique suivantes ont été obtenues à partir de la plaque de cuisson Cee® Apogee® 300 à une distance de 3 pieds (0,9 m) du système:</p> <p>Mode veille: 40 dB(A) Fonctionnement normal: 40 dB(A)</p>

1.7 Electrical

	High voltage is present in the machine. Disconnect power before servicing.	Une haute tension est présente dans la machine. Débranchez l'alimentation avant l'entretien.
	Stored electrical energy is present in the machine. Before servicing allow sufficient time for discharge.	L'énergie électrique stockée est présente dans la machine. Avant l'entretien, prévoyez suffisamment de temps pour la décharge.
	This unit must be connected to an outlet with proper grounding.	Cet appareil doit être connecté à une prise avec une mise à la terre appropriée.

1.8 Mechanical

	This machine may contain compressed gases which can provide motive force for components and can expand violently upon decompression. Disconnect N2 or CDA before removing any panels.	Cette machine peut contenir des gaz comprimés qui peuvent fournir une force motrice aux composants et peuvent se dilater violemment lors de la décompression. Débranchez le N2 ou le CDA avant de retirer les panneaux.
	Ensure that all panels are on and in their correct locations before powering up or operating.	Assurez-vous que tous les panneaux sont allumés et à leur emplacement correct avant la mise sous tension ou l'utilisation.
	When opening lids be aware of the pinch point at the hinge cover. Open lids only by using the handles on the lids.	Lorsque vous ouvrez les couvercles, faites attention au point de pincement au niveau du cache de la charnière. Ouvrez les couvercles uniquement en utilisant les poignées des couvercles.

1.9 Thermal

	Bake Plates can reach temperatures sufficient to cause severe burns and may remain hot for a long-time following operation. Do not service the machine until all surfaces have cooled to a safe thermal condition (e.g., room temperature).	Les plaques de cuisson peuvent atteindre des températures suffisantes pour provoquer de graves brûlures et peuvent rester chaudes longtemps après l'opération. N'entretenez pas la machine tant que toutes les surfaces n'ont pas refroidi à un état thermique sûr (par exemple, température ambiante).
---	---	---

1.10 Chemical

Cee® does not supply or dictate chemicals to be used in conjunction with the Cee® Apogee® 300 Bake Plate. Material data will be reviewed during





Cee® ne fournit ni n'impose aucun produit chimique à utiliser avec la plaque de cuisson Cee® Apogee® 300. Les données matérielles seront examinées lors de la

equipment design and configuration to ensure compatibility with the customer's proprietary process.

Prior to introducing new chemicals, refer to your chemical supplier's factory specifications and MSDS. Material Safety Data Sheets (MSDS) contain crucial information regarding chemical safety, including details about hazardous components, physical properties, spill and leak procedures, waste disposal guidelines, and personal protective equipment requirements for handling.

conception et de la configuration de l'équipement pour garantir la compatibilité avec le processus exclusif du client.

Avant d'introduire de nouveaux produits chimiques, reportez-vous aux spécifications d'usine et à la fiche signalétique de votre fournisseur de produits chimiques. Les fiches signalétiques (MSDS) contiennent des informations cruciales concernant la sécurité chimique, notamment des détails sur les composants dangereux, les propriétés physiques, les procédures en cas de déversement et de fuite, les directives d'élimination des déchets et les exigences en matière d'équipement de protection individuelle pour la manipulation.

	<p>Ensure chemical compatibility of all chemicals and materials being used inside the machine. This includes all wetted parts of the storage, supply, dispense, and waste systems.</p>	<p>Assurer la compatibilité chimique de tous les produits chimiques et matériaux utilisés à l'intérieur de la machine. Cela inclut toutes les parties mouillées des systèmes de stockage, d'alimentation, de distribution et de déchets.</p>
	<p>Potential for flammable Chemicals. No open flames/sparks.</p>	<p>Potential de produits chimiques inflammables. Pas de flammes nues/étincelles.</p>
	<p>Relieve pressure and shut off chemical valves before servicing supply lines, dispense valves or other components.</p>	<p>Relâchez la pression et fermez les vannes chimiques avant d'entretenir les conduites d'alimentation, les vannes de distribution ou d'autres composants.</p>
	<p>Ensure proper ventilation/exhaust is always used.</p>	<p>Assurez-vous qu'une ventilation/évacuation adéquate est toujours utilisée.</p>
	<p>Always wear appropriate Personal Protective Equipment. This includes safety glasses, gloves, and other equipment, as needed, to protect from mechanical and chemical hazards.</p>	<p>Portez toujours un équipement de protection individuelle approprié. Cela comprend des lunettes de sécurité, des gants et tout autre équipement, si nécessaire, pour se protéger des risques mécaniques et chimiques.</p>

Exhaust and fume management is important to prevent the release of hazardous materials and ensure a safe working environment. Users should assume that all fumes are hazardous and take appropriate precautions to ensure system exhaust is functional per the guidelines outlined in section 6 of this manual.

La gestion des gaz d'échappement et des fumées est importante pour empêcher le rejet de matières dangereuses et garantir un environnement de travail sûr. Les utilisateurs doivent supposer que toutes les fumées sont dangereuses et prendre les précautions appropriées pour garantir que l'échappement du système est fonctionnel conformément aux directives décrites dans la section 6 de ce manuel.

1.11 Lockout/Tagout Procedures and Information

Before servicing, turn off the machine and remove the power inlet cord by disconnecting the plug where it enters the machine.

Note: There are no LOTO (Lock Out/Tag Out) facilities supplied with the Cee® Apogee® 300 Flange Bake Plate. It is the responsibility of the customer/installer/end-user to ensure that the suitable LOTO devices are provided on utilities being supplied to the Cee® Apogee® 300 Flange Bake Plate in accordance with applicable laws, regulations, and/or company policies.

For more information, please contact [Cee® Customer Support](#).

1.12 Intended Use of Machine

The Cee® Apogee® 300 Flange Bake Plate is intended for use as a semiconductor/optical application machine.

The Cee® Apogee® 300 Flange Bake Plate is not intended for use in food or medical applications or for use in hazardous locations.

The Cee® Apogee® 300 Flange Bake Plate is intended for use only by trained personnel wearing the proper personal protective equipment. Anyone not trained in the proper use of the Cee® Apogee® 300 Flange Bake Plate and having not fully read this manual, should not operate the equipment.

The Cee® Apogee® 300 Flange Bake Plate is intended for use in a cleanroom environment to provide the proper processing conditions for substrates. If it is used outside of a cleanroom environment, substrate cleanliness may be compromised.

The Cee® Apogee® 300 Flange Bake Plate is not intended for use in a hazardous or explosive environment.

Normal Operating Conditions

The Cee® Apogee® 300 Flange Bake Plate is designed for indoor use only.

Ambient Temperature 10°C - 30°C

Relative Humidity ≤80%

Altitude up to 3000 m

Pollution Degree 2

Overvoltage Category II

Permissible Voltage Fluctuations 208-230VAC ±10%

	<p>If the Cee® Apogee® 300 Bake Plate is used in a manner not specified by Cee® or with accessories not provided by Cee® the protection provided by the equipment may be impaired.</p>	<p>Si la plaque de cuisson Cee® Apogee® 300 est utilisée d'une manière non spécifiée par Cee® ou avec des accessoires non fournis par Cee®, la protection fournie par l'équipement peut être altérée.</p>
---	--	---

2 Equipment Description

The Cee® Apogee® 300 Flange Bake Plate features a revolutionary intuitive interface, a space-saving design, and track-quality thermal accuracy and uniformity.

Fully programmable and user-friendly, the Cee® Apogee® 300 Flange Bake Plate features the accuracy and repeatability needed to eliminate processing variability from critical experiments. Recipes are easily entered, monitored, and stored with the convenient full-color touch screen interface and onboard DataStream™ Technology. Compact footprint, intuitive design, and unparalleled manufacturer experience add up to years of high-performance bake step processing, perfect for any low-volume or R&D laboratory processing environment.

2.1 User Controls

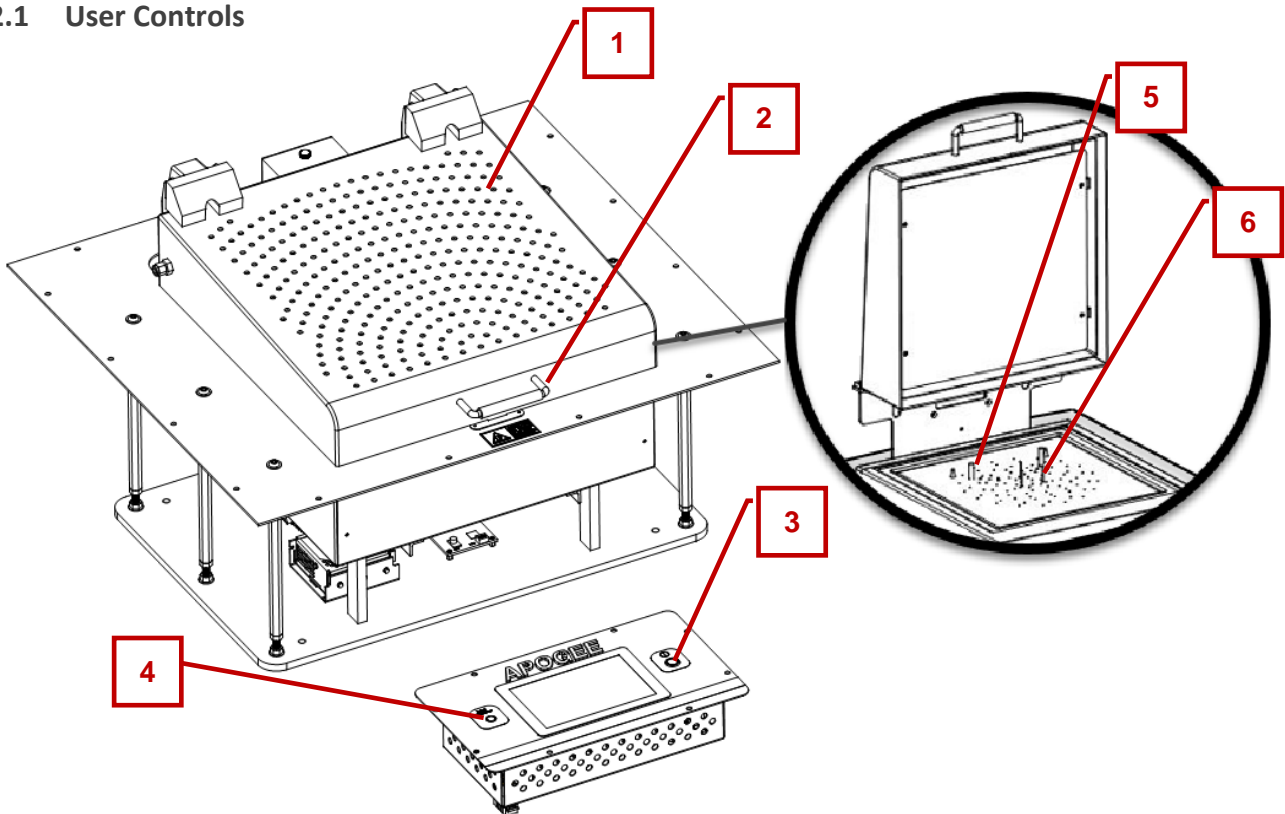
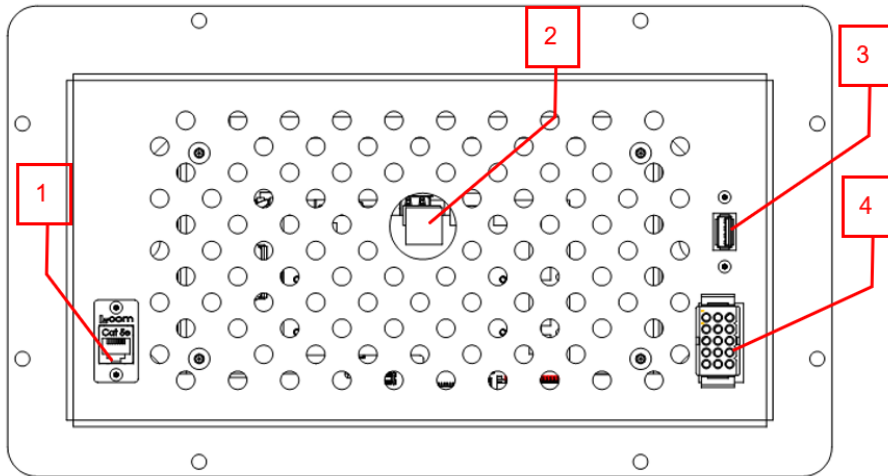

Figure 1: Cee® Apogee® 300 Flange Bake Plate User Controls

1. bake plate lid cover for the bake plate working surface
2. lid handle enables safe opening and closing of the lid
3. power button used to turn equipment off and on
4. user presence button¹ facilitates remote access
5. stop pins for precise wafer positioning
6. lift pins lifts and lowers the substrate

¹ See [DataStream™ Manual](#) for more information



1. Ethernet facilitates remote recipe writing and remote device control
2. AMP Communication² enables communication to the servo controller
3. USB Port³ facilitates data transfer
4. 15-pin connector supplies power & I/O to the GUI

2.2 Dimensions

- 28" (711.2mm) W x 25" (635mm) D x 17.25" (438.2mm) H
- machine weight 146lbs (66.2kg) *excluding accessories*

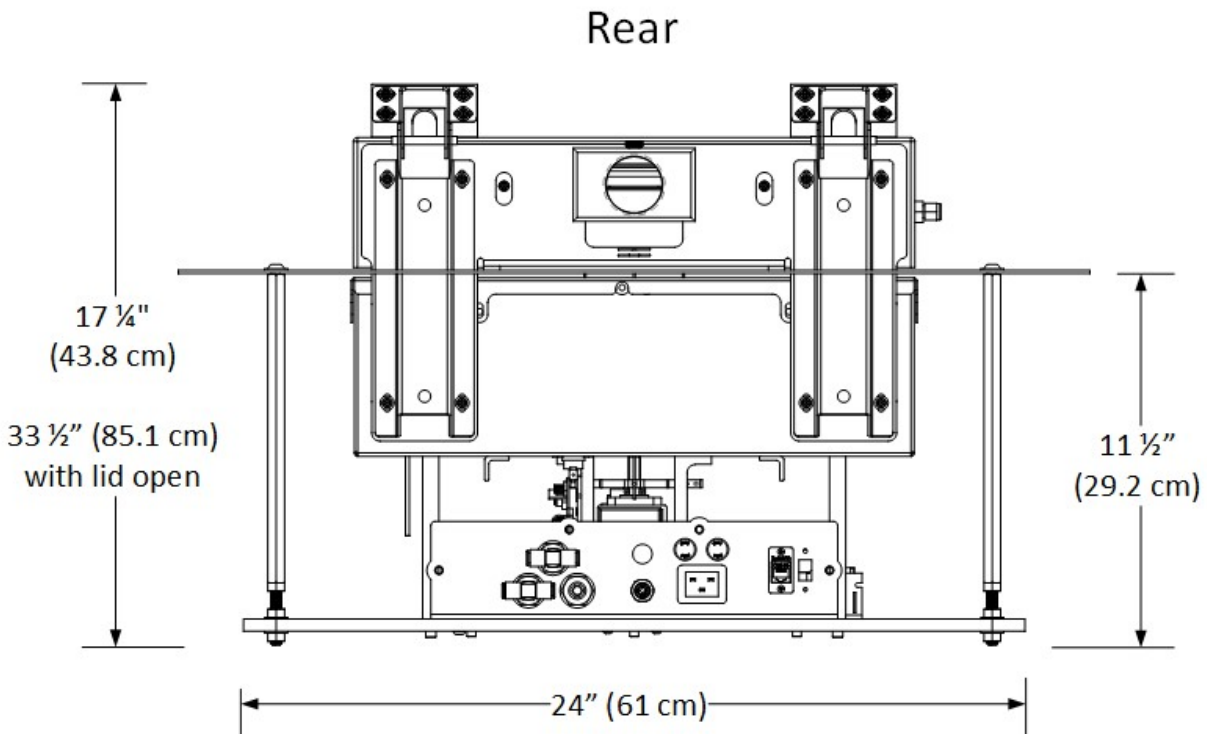

² Note that this is the same connector type as Ethernet but the two are NOT interchangeable. To do so will cause damage to the machine.

³ see DataStream™ Manual for more information

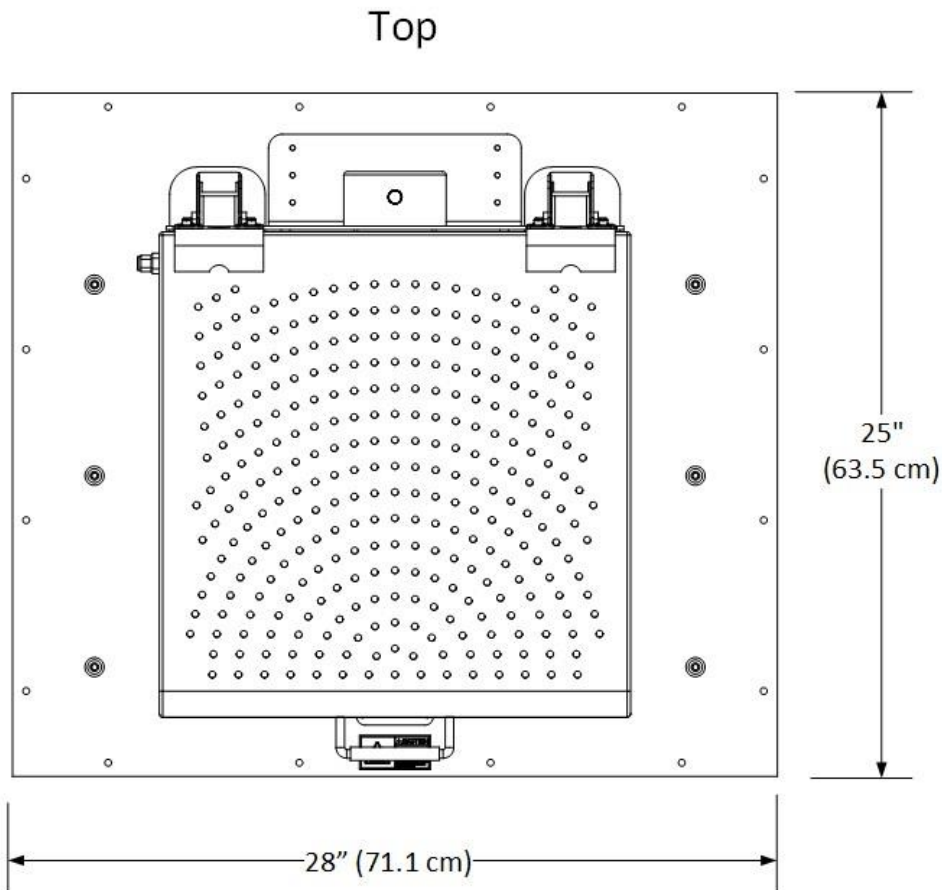

2.3 Features & Programmability

- compact design for minimized footprint
- 7" touch screen display with full-color alphanumeric-capable graphical user interface (GUI)
- durable wet bench design can be converted to a flange/deck mountable configuration
- supports unlimited bake process programs/program steps per recipe
- 0.1 second step time resolution (9,999.9 seconds maximum step time)
- three automated bake methods: contact, vacuum, proximity (N₂ or lift pins)
- bake plate auto-sizing for 100mm, 125mm, 150mm, 200mm and 300mm substrates⁴
- up/download DataStream™ process parameters via native USB and Ethernet ports
- program 10 specific proximity heights above surface in any sequence/combination
- height programmed in 0.1 increments with an overall range of 0-19mm
- exhausted hood for removal of process chemicals
- optional nitrogen purge for inert bake environment

2.4 Precision

- substrate sizes..... <10mm to 300mm round; 12" x 12" square
- temperature resolution 0.1°C
- temperature range..... ambient to 300°C (400°C optional)
- temperature uniformity..... ± 0.3% across working surface

⁴ Equipment may allow for custom sized substrates based on customer request.

2.5 Reliability

- industry-leading Cee® Apogee® reliability and uptime
- one-year full warranty on parts and labor
- complimentary remote technical support and application process assistance for the life of the product

2.6 NRTL

Beginning in June of 2024, all standard Cee® Apogee® 300 Flange Mounted Bake Plate models will proudly showcase the TÜV SÜD NRTL mark, a testament to our commitment to safety and quality.

The TÜV SÜD NRTL mark signifies compliance with North American safety standards, providing assurance of product safety and quality. Recognized by Authorities Having Jurisdiction (AHJs) and code officials throughout the US and Canada, the TÜV SÜD Mark is featured on millions of products sold nationwide. Customers can trust that products bearing the TÜV SÜD Mark meet rigorous safety standards established by independent testing and ongoing inspections.

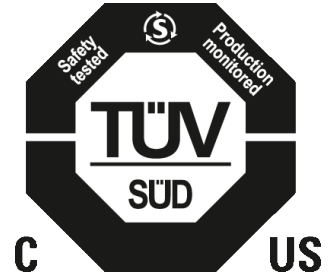

2.7 Utilities

- voltage ranges..... 208-230 VAC
- power requirements 3744W (16.3A) *max*
- exhaust port..... 2" (50.8mm) OD
- vacuum..... pump supplied
- exhaust..... 5-10cfm
- N₂..... 35psi

3 Installation

3.1 Mounting the Flange Process Module

The Cee® Apogee® 300 Flange Bake Plate is intended to be installed in a workstation, wet bench, or glove box. All components below the mounting flange should be inside a closed area and should not be exposed directly to chemicals or accessible to operators. The device should only be mounted on a non-flammable surface.

Clearance Requirements

Adherence to these requirements ensures adequate spacing, ventilation, and access to the detachable MAINS supply cords as needed.

- Equipment Rear 6" (15.24cm)
- Equipment Sides 3" (7.62cm)

Below are dimensions for the cut out and holes to be added into the working surface of the workstation, wet bench, or glovebox to properly lower and secure the flange mount unit. The equipment flange will accept #10 or M5 bolts for mounting.

Ensure the working surface can support the weight of the equipment. See Section 2.2 Dimensions for details.

Flange Cut Out

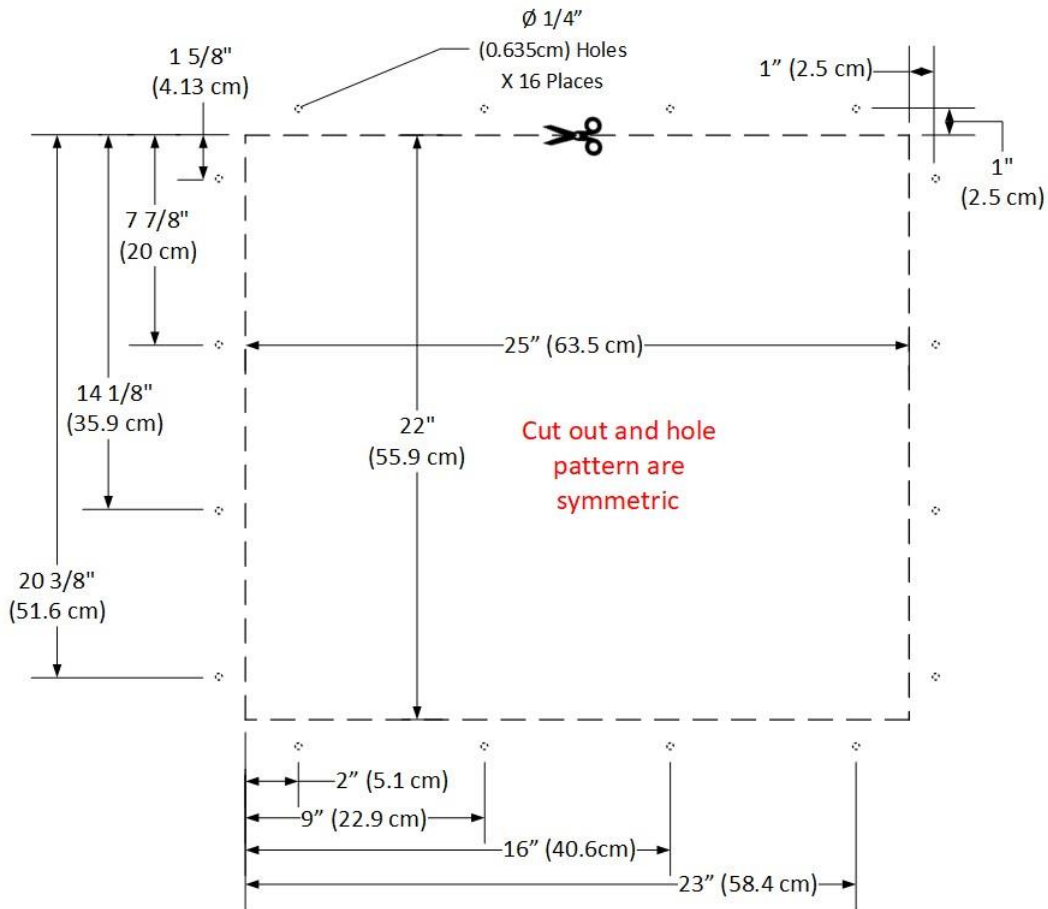

Figure 2: Apogee® Flange Mount Cut Sheet

3.2 Mounting the Flange Controller

The Cee® Apogee® Flange Controller is intended to be installed into the face of the workstation, wet bench, or glove box. The controller should not be exposed directly to chemicals and should be mounted in an ergonomic fashion.

Clearance Requirements

Adherence to these requirements ensures adequate spacing and ventilation.

Controller All Sides (Except Back) 1" (2.54cm)
 Controller Back..... 2 ½" (6.35cm)

Below are dimensions for the cut out to install the controller. The controller cable allows for it to be mounted up to 14 feet (4.26m) away. The controller flange will accept #10 or M5 bolts for mounting.

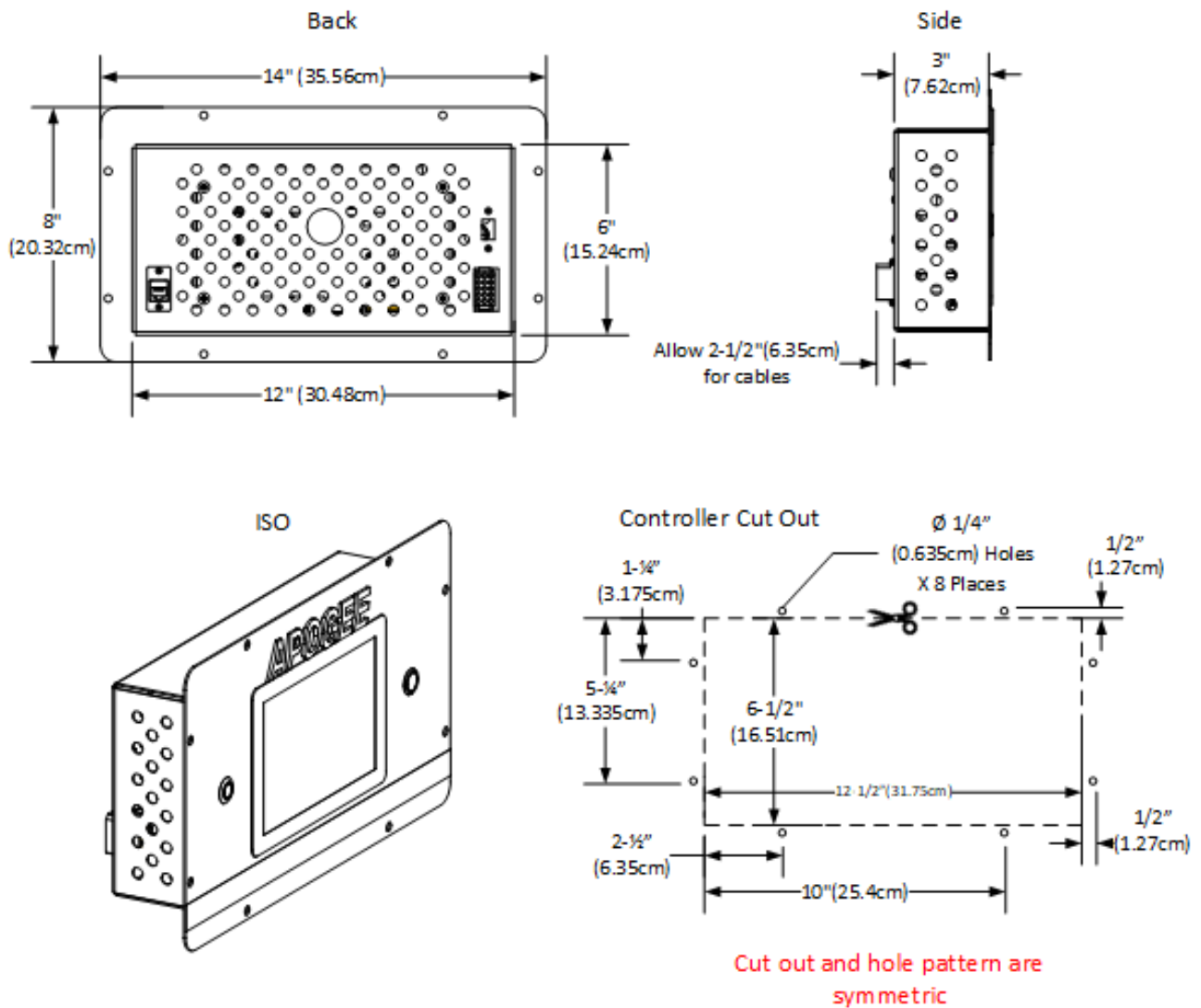

Figure 3: Cee® Apogee® Flange Controller Cut Sheet

3.3 Facilities Requirements

The Cee® Apogee® Flange Bake Plate requires the following utilities for operation.

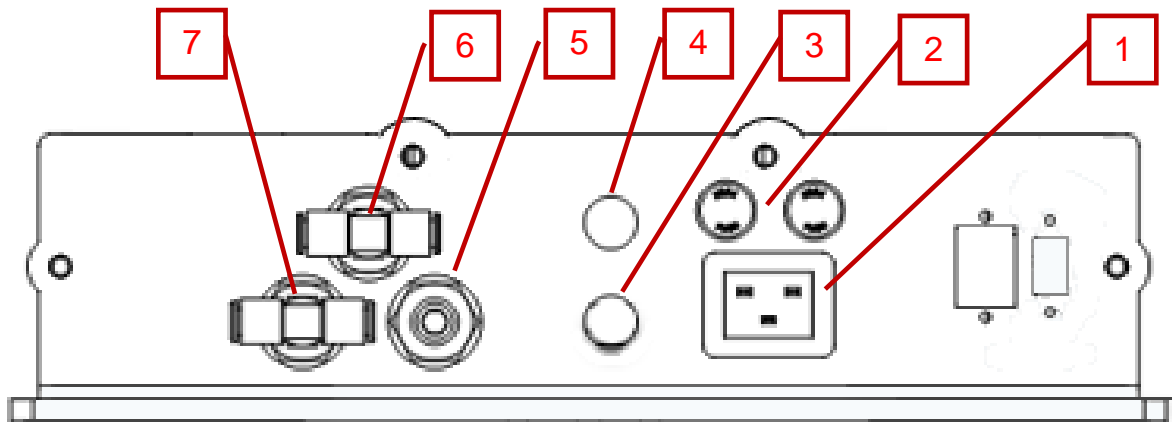

Figure 4: Cee® Apogee® 300 Flange Bake Facilities Connections

1. AC power in⁵single phase 208-230VAC at 16.3A
2. fusessystem protection fuses (Replacement: BK/MDA-20-R – 20A; 250VAC max)
3. accessory portenables communication with external I/O devices as needed
4. light tree(optional) light tree port, M12 4pin, female, 24VDC
5. vacuum accessoryconnection for accessories items (e.g., vacuum wands)
6. system N₂system nitrogen for proximity bake on the bake plate surface
7. system vacuumsystem vacuum for bake plate surface

3.4 Environment

The Cee® Apogee® 300 Flange Bake Plate should be operated in a clean, low humidity environment.

3.5 Unpackaging & Inspection

1. Lifting from the bottom of the unit, carefully remove from packing crate. Do not lift by any of the top covers or protrusions. Do not roll or turn the unit on its sides.
2. Remove packing foam and plastic wrap.
3. Place the Cee® Apogee® 300 Flange Bake Plate on a table of proper height and strength so that the controls and bake surface are at an ergonomically appropriate height.
4. Thoroughly check the machine for shipping damage. If physical damage is apparent, ***DO NOT APPLY POWER!*** Contact [Cee® Customer Support](#) immediately.

The following items are included with shipment:

- Cee® Apogee® Bake Plate
- (x2) stop pins
- temperature & humidity sensor
- power cord

⁵ 100-125VAC configuration is not available for Cee® Apogee® X-Pro II Workstation mounted process modules.

- operations manual (USB thumb drive)
- quick reference card

Optionally Included Items:

- vacuum pump
- light tree
- N₂ purge hood
- plastic tipped lift pins
- chill station

3.6 System Installation & Setup

*Please refer to the quick reference card supplied with the tool.

**Note that process modules intended for use with the Cee® X-Pro II Workstation will arrive preinstalled. See the Cee® X-Pro II Workstation Operations Manual for installation instructions.

1. Mount the equipment into the workstation, wet bench, or glove box as described in Section 3.2 Mounting the Flange Controller
2. Carefully clean the bake surface to remove contaminants.
3. Connect utilities per the reference diagram in Figure 4: Cee® Apogee® 300 Flange Bake Facilities Connections
4. Connect the temperature & humidity sensor to the CAN terminal.
5. Connect the vacuum supply to the vacuum fitting. (System vacuum <33kPa abs)
6. Connect the flange controller to the Apogee® Flange process module via the 15-pin cable and RJ45 connector. The RJ45 connector is labeled 'AMP' and should *only* be connected to the amp port in the center of the back of the main controller. **Connecting this cable to the incorrect port may cause damage to the equipment.** See Figure 5 for details.
7. Plug in the machine using the supplied Cee® shielded cables.

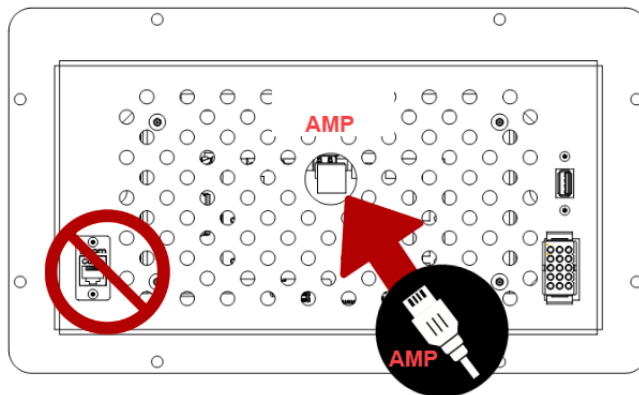

Figure 5: Rear Controller RJ45 Connection

3.7 Start Up

Once the preliminary setup steps outlined in section 3 have been completed, press the lighted *Power* switch to turn the tool on. The display will cycle through a series of boot screens before arriving at the main login screen.

Enter default administrative login credentials:

Username: admin
Password: admin2

3.8 System Checks

On the **Process** screen, navigate to **Tools>Manual Control** and perform the following system checks for initial validation of the Cee® Apogee® 300 Flange Bake Plate.

Set Lift Pins

Select a **Control** of *Lift Pins* and an **Action** of *Set*. Enter a value into the **Height** field and tap **Apply**. Verify *Lift Pin Height* readings respond to changes on the *System Values* list.

Apogee Bake Process Recipes About Tools - admin

Parameter	Actual	Set Point
Plate Temperature	26.2 °C	--
Lift Pin Height	0.0 mm	0.0 mm
Bake Method	Contact	Contact
Ambient Temperature	27.2 °C	
Humidity	45.2 %	

System Controls

Control: Lift Pins

Action: Set

Height: 0 mm

Set lift pins to 0 mm

APPLY

Inset supplied stop pins into the desired holes on the bake plate surface. These stop pins keep the substrate centered on the bake plate surface. Holes closest to center are for 100mm substrates. From center, stop pin locations are for 100mm, 125mm, 150mm, 200mm, 300mm substrates respectively.

Bake Methods

Vacuum

Set **Bake Method** to *Vacuum*. Place a substrate on the center of the bake plate and check that the vacuum holds the substrate.

Apogee Bake Process Recipes About Tools - admin

Parameter	Actual	Set Point
Plate Temperature	26.1 °C	--
Lift Pin Height	0.0 mm	0.0 mm
Bake Method	Vacuum	Vacuum
Ambient Temperature	27.2 °C	
Humidity	43.5 %	

System Controls

Control: Bake Method

Action: Select Method

Method: Vacuum

Bake using Vacuum method

APPLY

Proximity

Set **Bake Method** to *Proximity*. This will turn off the vacuum and purge N₂ to float the substrate above the bake plate surface.

Apogee Bake Process Recipes About Tools - admin

Parameter	Actual	Set Point
Plate Temperature	26.1 °C	--
Lift Pin Height	0.0 mm	0.0 mm
Bake Method	Proximity	Proximity
Ambient Temperature	27.1 °C	
Humidity	43.0 %	

System Controls

Control: Bake Method

Action: Select Method

Method: Proximity

Bake using Proximity method

APPLY

Contact

Set the **Bake Method** to **Contact**. This will turn off vacuum and N₂. Remove the substrate.

The screenshot shows the Apogee Bake interface. On the left, the 'System Values' table displays the following data:

Parameter	Actual	Set Point
Plate Temperature	26.1 °C	--
Lift Pin Height	0.0 mm	0.0 mm
Bake Method	Contact	Contact
Ambient Temperature	27.2 °C	
Humidity	43.3 %	

On the right, the 'System Controls' panel shows the 'Control' dropdown set to 'Bake Method', the 'Action' dropdown set to 'Select Method', and the 'Method' dropdown set to 'Contact'. A blue 'APPLY' button is at the bottom.

Temperature & Humidity Sensor

Ensure the temperature & humidity sensor is functioning by verifying that **Ambient Temperature** and **Humidity** readings are present on the *System Values* List.

The screenshot shows the Apogee Bake interface. On the left, the 'System Values' table displays the following data:

Parameter	Actual	Set Point
Plate Temperature	24.4 °C	--
Lift Pin Height	19.0 mm	19.0 mm
Bake Method	Contact	Contact
Ambient Temperature	25.2 °C	
Humidity	45.1 %	
Empty Sensor	False	

On the right, the 'System Controls' panel shows the 'Control' dropdown set to 'Bake Method', the 'Action' dropdown set to 'Select Method', and the 'Method' dropdown set to 'Contact'. A blue 'APPLY' button is at the bottom.

Enable & Test Plate Temperature

Use the **Control** drop-down to select **Plate Temperature** then select an **Action** of **Set**, enter the desired plate temperature for your application, and tap **Apply**. *Note that the *System Values* list displays a Set Point of null (--).

The screenshot shows the Apogee Bake interface. On the left, the 'System Values' table displays the following data:

Parameter	Actual	Set Point
Plate Temperature	26.2 °C	--
Lift Pin Height	0.0 mm	0.0 mm
Bake Method	Contact	Contact
Ambient Temperature	27.2 °C	
Humidity	43.4 %	

On the right, the 'System Controls' panel shows the 'Control' dropdown set to 'Plate Temperature', the 'Action' dropdown set to 'Set', and the 'Value' input field set to '90'. A blue 'APPLY' button is at the bottom.

Change the **Control** selection to **Plate Temperature** then select **Enable** from the **Action** and **Value** dropdowns and tap **Apply**. Note that the temperature entered in the previous step is now displayed as the **Set Point** in the *System Values* list. The **Actual** temperature in the *System Values* list will increase/decrease as the bake surface heats/cool.

Apogee Bake Process Recipes About Tools - admin

System Values

Parameter	Actual	Set Point
Plate Temperature	27.5 °C	90.0 °C
Lift Pin Height	0.0 mm	0.0 mm
Bake Method	Contact	Contact
Ambient Temperature	27.2 °C	
Humidity	43.2 %	

System Controls

Control: Plate Temperature

Action: Enable

Value: Enable

Enable temperature controller

APPLY

Once these operations have been validated, the Cee® Apogee® 300 Flange Bake Plate is ready for use. Begin by creating a recipe. Refer to the [DataStream™ Manual](#) for more information and refer to section 4 of this manual for Bake Plate specific DataStream™ features.

****In the event of a fault condition, power cycle the tool to restore function***

4 DataStream™ Technology

This section covers information specific to the Apogee® 300 Flange Bake Plate and is intended as a companion to the DataStream™ Technology Software Manual. **Please review the DataStream™ Operations Manual** for detailed guidance on software usage.

4.1 Safety Temperature Warning

The safety temperature warning feature is intended as a safeguard against operator injury. When the bake surface exceeds the temperature threshold specified by the equipment administrator, a Hot (~°C) watermark is displayed on all screens. When bake surface temperatures cool to temperatures less than the threshold specified by the equipment administrator, the watermark is cleared.

See Section 4.8- Tool Specific Settings – Apogee® Bake Plate for details on how to enable and configure this setting.

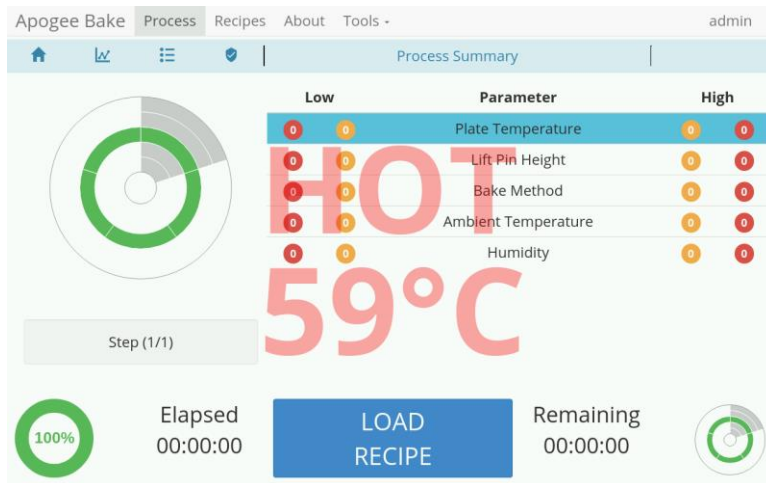

4.2 Timer Controls

Located under the Tools menu, the timer controls feature provides convenient access to and tracking of manual process controls. Individual timers can be initiated concurrently, and users can toggle between count up and count down functions by tapping the button. On tapping *Start*, the *Count Up* timer will initiate. The *Count Down* timer allows for a user specified starting value (default is 10 seconds.) When the countdown hits zero the tool will elicit an audible alarm, the timer will continue to countdown into the negative, and the timer will turn red to further indicate that time has expired.

From the Timer Controls screen, users can raise/lower lift pins and select the desired bake method. Green indicates the current mode. Lift pins will lower to zero and raise to the lift pin idle position configured in system settings. (See 4.8- Tool Specific Settings – Apogee® Bake Plate for details on how to configure the lift pin idle position.)

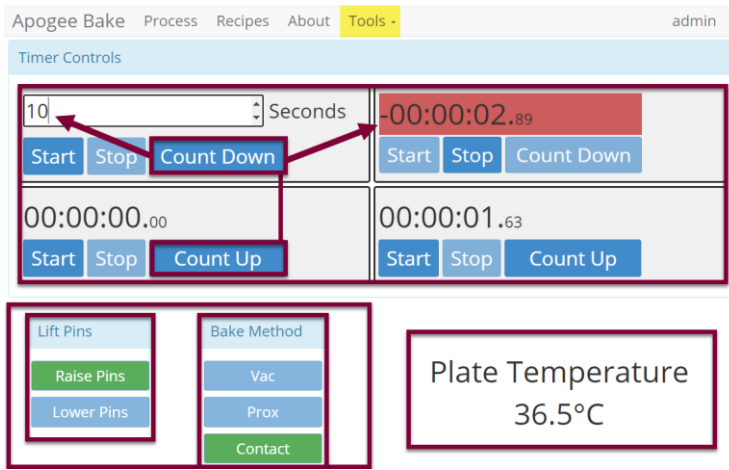

4.3 System Parameters

Parameter	Actual	Set Point	Status
Plate Temperature	59.4 °C	60.0 °C	In Range
Lift Pin Height	19.0 mm	19.0 mm	In Range
Bake Method	Contact	Contact	In Range
Ambient Temperature	26.5 °C		In Range
Humidity	44.8 %		In Range

- Plate Temperature⁶**----- current temperature of the hot chuck displayed against target set point in degrees Celsius
- Lift Pin Height**----- height of exposed lift pins in relation to chuck in millimeters; precision control settings range from 0.0-19.0
- Bake Method**----- dictates manner in which substrate is heated; vacuum, contact, proximity, lift pins; refer to Apogee® Bake Plate Operations Manual for more information
- Ambient Temperature**----- air temperature of environment where equipment is housed
- Humidity⁷**----- ambient relative humidity of environment where equipment is housed

4.4 Manual Controls – Apogee® Bake Plate

The Manual Control activity is an advanced feature that allows users to run most operating processes outside of a recipe. This mode is useful for tasks such as prototyping processes, verifying equipment operation, and recovering from aborted processes. To access the activity, navigate to **Tools > Manual Control**. Actual and set point parameter values are displayed on the left. Available controls will be selected from the dropdown menu on the right.

If using remote feature, the user must have confirmed their local presence to execute manual commands. See section 7.3 for more detail on Local Presence.

⁶ A process will not wait to achieve desired temperatures before moving onto the next step. Utilize preconditions or manual controls to ensure platen temperatures are in range before a process is initiated.

⁷ Both Ambient Temperature and Humidity are measured via a custom sensor board mounted next to a ventilation inlet inside the tool. If sensor is disconnected, default of -1.1 is displayed.

Apogee Bake Process Recipes About **Tools -** admin

System Values

Parameter	Actual	Set Point
Plate Temperature	24.5 °C	--
Lift Pin Height	19.0 mm	19.0 mm
Bake Method	Contact	Contact
Ambient Temperature	26.7 °C	
Humidity	41.4 %	

System Controls

Control What do you want to control?

What do you want to control?

Plate Temperature

Lift Pins

Bake Method

Please check your values before applying the change.

APPLY

Plate Temperature

System Values

Parameter	Actual	Set Point
Plate Temperature	41.5 °C	--
Lift Pin Height	-1.0 mm	5.0 mm
Bake Method	Contact	Contact
Ambient Temperature	25.1 °C	
Humidity	45.5 %	

System Controls

Control Plate Temperature

Action Set

Value 45 °C

Please check your values before applying the change.

Select a **Control** of *Plate Temperature*.
 Select an **Action** of *Set*.
 Enter the desired value in °C.

Click APPLY

The Temperature Controller must be enabled to initiate the heating process. See next step.

System Values

Parameter	Actual	Set Point
Plate Temperature	41.9 °C	45.0 °C
Lift Pin Height	-1.0 mm	5.0 mm
Bake Method	Contact	Contact
Ambient Temperature	25.0 °C	
Humidity	44.4 %	

System Controls

Control Plate Temperature

Action Enable

Value Enable

Enable temperature controller

Select an **Action** of *Enable*.
 Select a **Value** of *Enable* or *Disable* to activate or deactivate the temperature controller.

Click APPLY

Note that the heating process has been initiated and a plate temperature set point has populated on the system values list. When a value of *Disabled* is selected, a Set Point of - - is displayed and the heating process is terminated.

System Controls

Control

Action

Select an **Action** of *AutoTune*.

Click APPLY

User must first define the set point and enable temperature controller.

Useful for refining the temperature control for a given setting – note that this may take a significant amount of time.

System Controls

Control

Action

Target °C

Rate °C / Minute

Select an **Action** of *Ramp*.

Enter the **Target** temperature.

Enter the desired ramp **Rate**⁸ (between 1-6°C per minute).

Click APPLY

Lift Pins

Parameter	Actual	Set Point
Plate Temperature	42.9 °C	45.0 °C
Lift Pin Height	10.0 mm	10.0 mm
Bake Method	Contact	Contact
Ambient Temperature	25.0 °C	
Humidity	44.7 %	

System Controls

Control

Action

Height mm

Set lift pins to 10 mm

Select a **Control** of *Lift Pins*.

⁸ Cee® does not offer active cooling on bake plates however, the ramp feature can be used to reduce the rate of cooling beyond what ambient conditions allow.

Select an **Action** of **Set**.
Enter the target height (between 0-19mm).

Click APPLY

Note that the lift pin height set point has populated on the system values list.

System Controls

Control	Lift Pins
Action	Go Home

Select an **Action** of **Go Home**.

Click APPLY

Lift pins recede beneath the surface of the hot plate until they contact the homing flag for recalibration of position.

System Controls

Control	Lift Pins
Action	Step
Step Size	19 mm
Direction	Up

Select an **Action** of **Step**.
Enter the desired **Step Size** (between 0-19mm).
Select the preferred **Direction**.

Click APPLY

System Controls

Control	Lift Pins
Action	Raise Pins

Select an **Action** of **Raise Lift Pins**.

Click APPLY

Set pins to the Lift Pin Idle Position specified in. Review the Apogee® Bake Plate Operations Manual for more information.

System Controls

Control

Action

Select an Action of *Lower Lift Pins*

Click APPLY

Lift pins recede just beneath the surface of the hot plate to facilitate contact with the substrate.

System Controls

Control

Action

Target mm

Rate mm/min

Select an Action of *Ramp*

Enter the Target (between 0-19mm)

Select the preferred ramp Rate (between 0-200mm/min)

Click APPLY

Bake Method

System Values		
Parameter	Actual	Set Point
Plate Temperature	45.3 °C	45.0 °C
Lift Pin Height	10.0 mm	10.0 mm
Bake Method	Contact	Contact
Ambient Temperature	25.1 °C	
Humidity	44.7 %	

System Controls

Control

Action

Method

Bake using Contact method

Select a Control of Bake Method
Select the desired Method (Vacuum, Proximity, or Contact)

Click APPLY

Review the Apogee® Bake Plate Operations Manual for more information on Bake Methods.

4.5 Preparation

Users with sufficient privileges can **Prepare** equipment to run a recipe. This feature is useful for preconditions and parameters that take a significant amount of time such as hot chuck and platen temperatures. To initiate this feature, navigate to the **Recipes** tab, click **Load** to access the recipes list and select the desired recipe, then click **Prepare**.

The screenshot shows the Apogee Bake Process interface. The top navigation bar includes 'Apogee Bake Process', 'Recipes' (highlighted), 'About', and 'Tools -'. The user is logged in as 'admin'. The main content area is titled 'Viewing Recipe- Test_Red_Recipe'. On the left, there is a 'Recipe Controls' sidebar with buttons for 'Load', 'Prepare' (highlighted with a red box), 'Run', and 'New'. The main area displays the recipe details: Name 'Test_Red_Recipe', Plate Temperature '180 °C', and a table with columns 'Step', 'Time (seconds)', 'Process Method', and 'Pin Height (mm)'. The table contains one row: Step 1, Time 60, Process Method 'Contact', and Pin Height (mm) is empty.

***Preparation processes cannot be initiated when the equipment is already in use.**

Local Display – When a **Prepare** command is entered, the user or device with active control of the machine receives an alert. This prompt includes the user and recipe to be prepared. The user with control of the machine can refuse the request by selecting **Abort** or accept the request by tapping **OK**.

In the absence of a response, the request is auto accepted after two minutes.

The screenshot shows a local display alert dialog box. The text inside the dialog reads: 'User (admin) attempting to set temperature for recipe: Test_Red_Recipe. Press OK to continue or ABORT to cancel.' Below the text is a large blue button labeled 'OK' and a smaller red button labeled 'Abort'. A timer '00:00:01' is visible in the bottom right corner of the dialog. At the bottom of the screen, there is a 'Recipe Preparation' status bar with the 'Abort' button.

Preparation In Progress – progress toward the specified precondition(s) is displayed to the user with verified local presence.

Plate Temperature(130.0 °C) - Within -5% and +5% of 180 °C

Waiting on preconditions to be in range for recipe ...
(PREHEAT) - Test_Red_Recipe

100% Elapsed 00:00:18 **ABORT** Remaining 00:00:00

Preparation Complete – indicates that the equipment has reached all specified preconditions and the recipe can be initiated. Upon clicking **OK** the user is directed to the *Process* screen to begin the recipe.

Test_Red_Recipe
Ready to run!

OK

00:00:02

Recipe Preparation

**During recipe preparation the Prepare and Run commands are disabled to ensure no interruption to precondition processes.*

4.6 Running Recipes

1. Select Recipe Page

Apogee™ Bake Process **Recipes** About Tools -

2. Load Recipe

Recipe Controls

Load

New

3. Search For, Identify, & Select Recipe

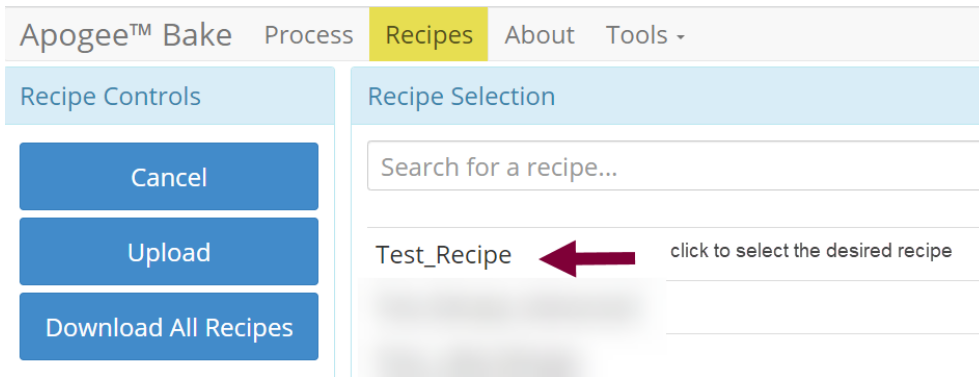

4. Run Recipe

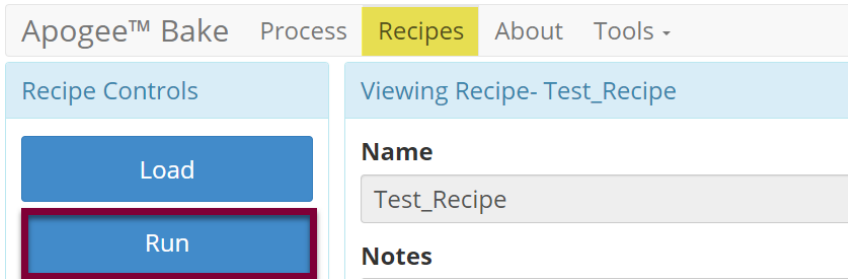

5. Start Recipe

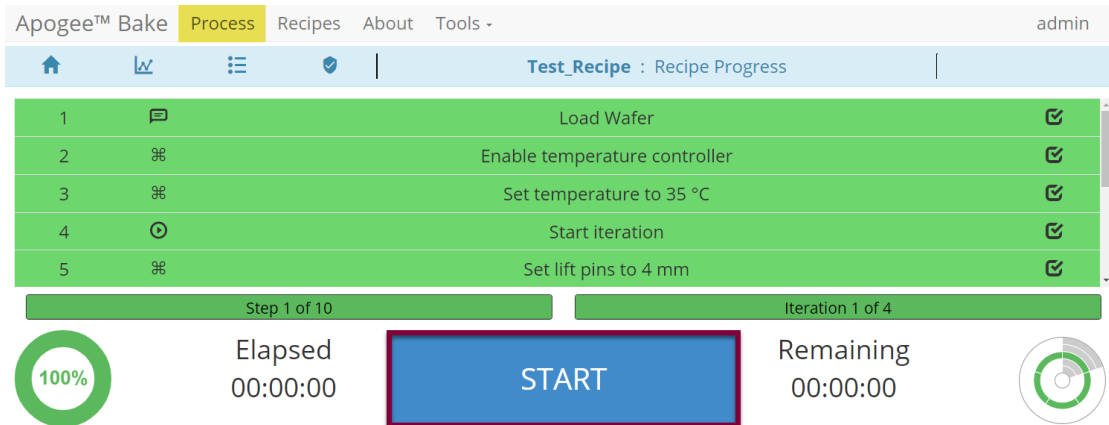

6. Recipe Progression

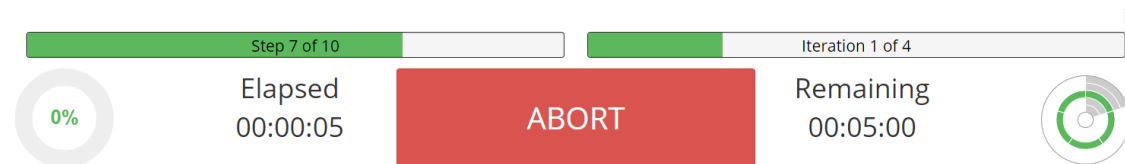

*Users may be required to follow prompts on the screen during recipe execution.

4.7 Editing Recipes

Step	Time (seconds)	Process Method	Pin Height (mm)
1	60	Contact	
2	30	Contact	
3	30	Contact	
4	60	Proximity	

4.8 Tool Specific Settings – Apogee® Bake Plate

Temperature Offset Calibration (°C)	offset used by temperature controller to calibrate reported chuck temperature
Lift Pin Idle Position	specify default position of lift pins between processes
Lift Pin Offset	offset used for calibration of lift pin positioning
Safety Temp(°C)⁹	when hot plate temperature exceeds this value, <i>HOT(°C)</i> watermark is displayed on all screens
Idle Temp(°C)¹⁰	specify temperature equipment will reduce to during periods of inactivity ¹¹
Time Before Idle(minutes)¹²	length of time (minutes) between processes before the thermal controller reverts to idle temperature specified

⁹ A value of 0 will disable the safety temperature watermark.

¹⁰ A value of 0 will disable the thermal controller (temperature off) after specified *Time Before Idle(minutes)* – specified idle temperature settings will only facilitate *reduction* in temperature.

¹¹ Inactivity is defined as time since last manual or recipe-controlled process – screen interactions will not delay idle temperature.

¹² A value of 0 in the *Time Before Idle(minutes)* field will disable the idle temperature feature and the bake surface will remain at the most recently specified temperature indefinitely or until a new temperature is specified.

5 Bake Plate Theory

Hotplate bake processing has increased in popularity since the early 1980s. Previously the most common technique for film drying and curing was the convection oven. Bake plates, also known as hotplates, offer several advantages in the form of increased throughput, increased uniformity and reproducibility, and decreased particle contamination. In a typical bake process, the substrate quickly rises to temperature. Drying and curing steps generally take about one minute. This contrasts with traditional oven processes which generally take thirty minutes or more.

5.1 Bake Plates vs Conventional Ovens

Bake plates have several advantages over conventional ovens.

- decreased bake time
- increased reproducibility
- better film quality

This section will describe these differences and set a few guidelines for using bake plates.

Stratification, the formation of different temperature zones, is a problem associated with convection ovens and can severely affect film quality and reproducibility.

The heating rate of a substrate in an oven depends not only on the heated air flow past a substrate but also on its proximity to other cold substrates. Thus, the heating rate for each substrate in a cassette of substrates that are being baked will be less than if each substrate is baked alone.

In addition, substrates near the ends of a cassette heat faster than the substrates in the middle, producing a non-uniform heating.

Particle generation also occurs within a standard oven. In a forced-air convection oven, substrates are commonly exposed to a flow of particle laden air for at least thirty minutes.

During resin film cures, the substrates will be exposed to considerable particulate contamination. The substrates are vulnerable since the film may still contain solvents and during this *soft* state the film is very susceptible to having particle adhere to it.

5.2 The Skin Effect

Another disadvantage of normal oven baking results from baking substrates from the *outside in*. Since heat is applied to the outer surface of the film first, a skin forms on the surface of the film, trapping solvents. Upon vaporizing, these solvents form blisters or bubbles which results in adhesion loss or even bulk film failure. This problem prevails in processes involving thick film resins, e.g., polyimides.

No skin effect occurs on a hotplate since hotplate baking heats the substrate from the bottom up. This *inside out* approach offers advantages for thick films since solvents in the film nearest the substrate are baked off before the film surface seals over.

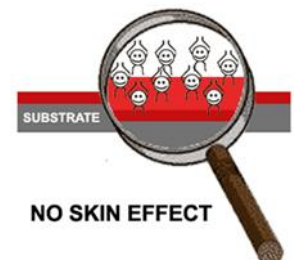
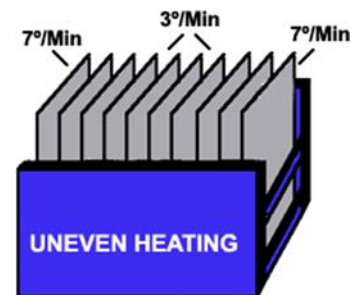
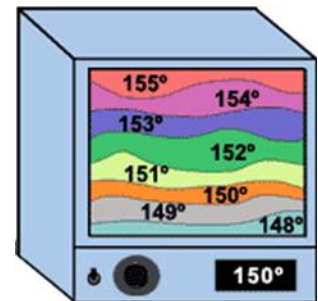

5.3 Hotplate Bake Variables and Methods

A typical bake process consists of preheating the surface to a known temperature, loading the substrate onto the surface for a specific length of time and removing it promptly at the end of the cycle. The selection of the temperature and time values used as well as the bake method employed all affect the overall performance of the process.

5.4 Bake Temperature

The bake temperature used is dependent on several factors. The material and substrate being baked as well as the results desired are key factors to be considered in developing a bake process

In general, hotplate baking will be performed at temperatures slightly higher than those used in oven bake processes. The film being baked will reach a temperature somewhere between the temperature of the hotplate and the ambient air above the film. As an example, with a hotplate surface temperature of 115°C, a layer of photoresist on a silicon wafer will reach a final temperature of about 105°C after a few seconds. Thicker substrates and/or substrates with lower coefficients of thermal conductivity will require even higher temperatures to compensate for this phenomenon.

5.5 Bake Methods

Another important factor is the method of bake. Cee® hotplates allow for three distinct bake methods:

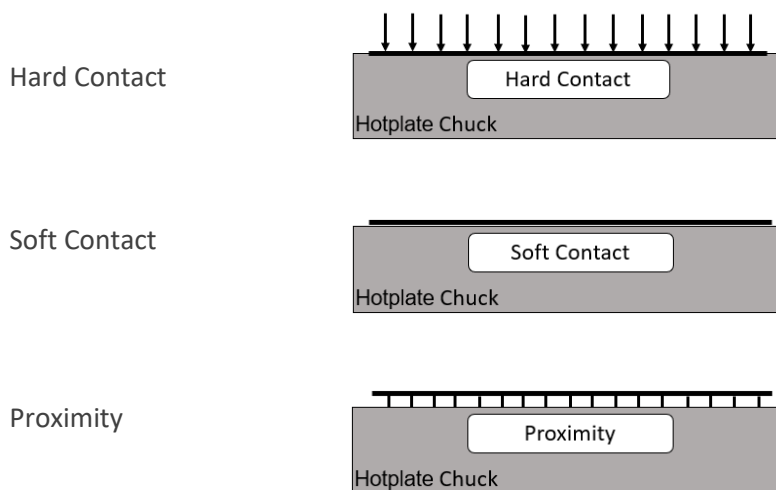

In a hard contact bake, the substrate is held onto the hotplate surface by the application of vacuum to the underside of the substrate. Small holes are machined into the hotplate surface in a pattern which optimizes vacuum distribution without the formation of cold spots or warping of the substrate. This method is usually preferred for silicon and other flat substrates where back side contact is not a problem.

Soft contact baking uses gravity alone to hold the substrate to the hotplate. This method generally offers less uniformity since the substrate-hotplate thermal interface is not as efficient.

Proximity baking is accomplished by forcing nitrogen through ports in the hotplate surface. This forces the substrate to float at a distance of one to four millimeters (25-100µm) above the hotplate surface. Proximity baking allows for a slower warm-up than contact bake methods and can be advantageous when baking thick films where blistering would otherwise be a problem.

Another advantage of proximity baking is that often, cambered, or warped substrates can be baked with a high degree of uniformity. This is usually not possible with the contact methods since it is not possible to achieve a vacuum under a substrate that is not flat to start with. Processing cambered substrates with the soft contact

method creates hot spots where the substrate touches the hotplate and cold spots where it does not. It should be noted as well that this type of proximity process is *self-leveling* in that substrate will tend form a uniform gap to the hotplate surface.

Proximity baking also offers the unique advantage of allowing hotplate processing without touching the bottom side of the substrate. An example of this application is photomask processing. In processing these relatively thick glass plates it is important that the backside of the glass not directly touch the hotplate since rapid heating will cause micro-fractures in the glass. By performing the entire bake process in proximity mode, the integrity of the substrate is not endangered, and the uniformity is excellent.

5.6 Bake Time

The selection of the bake time parameter plays an important role in the reproducibility of the bake process. Substrate thermal properties and the choice of bake method greatly affect the amount of time necessary for the substrate, and therefore film temperature, to stabilize during the bake. Thicker substrates and the use of proximity bake methods will increase the time necessary for the film to reach its final temperature. It is important that most of the baking action in the film take place after this temperature is reached. A silicon wafer will reach a stable temperature within a few seconds and so it is traditional to adjust photoresist bake processes to be completed in 60-90 seconds with an appropriate bake temperature.

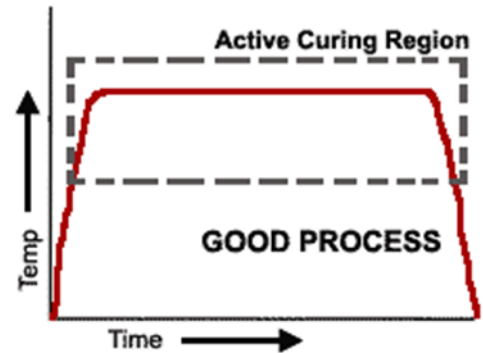

For thicker substrates such as photomask and ceramic modules, the increased time necessary to heat the larger mass of the substrate results in bake times approaching five minutes. It should be noted that these substrates can be processed with higher temperature and shorter bake times, but reproducibility may suffer. If the bake time is too short, a significant amount of the actual bake process will take place during the loading and unloading steps as well as while the substrate is cooling after removal from the bake plate. This is an unstable condition since it is very difficult to exactly reproduce conditions during these steps.

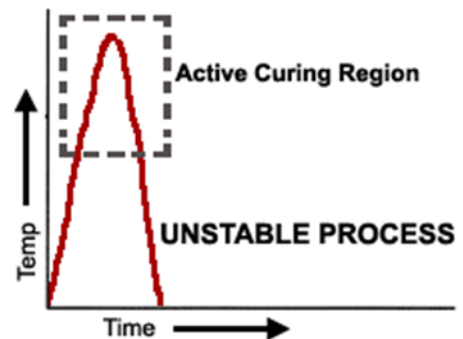

In general, the temperature-time relationship in a bake process can be taken as a dose of the (temperature) x (time) product. Increasing the bake temperature results in a need for decreasing bake time. The limits for both parameters can be reached when the process is no longer reproducible or when the physical temperature limitations of the resin or substrate have been reached.

5.7 Exhaust Cover

The design of the Cee[®] exhaust cover promotes dissipation of vapors removed from a substrate placed on the chuck, without drawing air across the chuck surface.

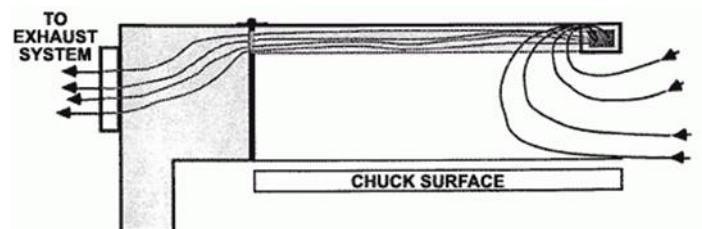

5.8 Oven vs Bake Plate Examples

The chart below presents process examples for commonly used resins. These figures should *not* be used as a rigid guideline since the best method with a particular baking application can only be achieved through experimentation.

Application

Positive Photo Resist

Oven Bake

90°C, 30 minutes, Polyimide beta (partial imidization)

135°C, 30 minutes, Polyimide alpha (solvent removal)

Hotplate Bake

115°C, 30 seconds, hard contact bake, Polyimide beta (partial imidization)

150°C, 15 seconds, proximity bake, 150°C-90 seconds, hard contact bake, Polyimide alpha (solvent removal)

5.9 Reflow Soldering

Bake plate processing heats the substrate and the solder without applying heat directly to the devices on the board. Using a combination of proximity and hard-contact bakes, the bake profile can be adjusted to suit any process.

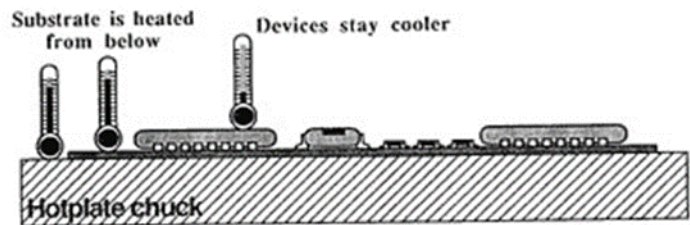

5.10 Bake Plate Process Troubleshooting

As with spin coating process, there are no absolute rules for bake plate processing, only general guidelines. The following is a list of issues to consider for specific bake plate process problems.

Film overbaked

bake temperature too high.....reduce temperature

bake time too longdecrease bake time

Film underbaked

bake temperature too lowincrease temperature

bake time too shortincrease bake time

Film blistering or cracking

unstable balance in temp/time parametersdecrease temp/increase time

warm-up time too fastuse proximity bake to preheat substrate

Non-uniform bake

unstable balance in temp/time parametersdecrease temp/increase time

operating with exhaust lid raisedlower the exhaust lid

unstable ambient conditionsprotect against major fluctuations

bake time too shortincrease bake time





bake plate surface contaminatedclean surface of bake plate

6 Preventative Maintenance

This section provides personnel with procedures and guidelines for maintaining a Cee® Apogee® Bake Plate.

6.1 Service and Repairs

Safety Notice: Important Repair Information for Cee® Equipment

	In order to maintain safety and performance standards, only authorized representatives of Cee® are permitted to conduct repairs or alterations on Cee® equipment.	Afin de maintenir les normes de sécurité et de performance, seuls les représentants autorisés de Cee® sont autorisés à effectuer des réparations ou des modifications sur l'équipement Cee®.
	When servicing the machine, use only replacement parts made or recommended by Cee®.	Lors de l'entretien de la machine, utilisez uniquement des pièces de rechange fabriquées ou recommandées par Cee®.
	Use only Cee® supplied shielded cables with this machine.	Utilisez uniquement les câbles blindés fournis par Cee® avec cette machine.
	Unauthorized repairs may lead to serious risks such as equipment malfunction, damage, personal injury, or even death.	Les réparations non autorisées peuvent entraîner des risques graves tels qu'un dysfonctionnement de l'équipement, des dommages, des blessures corporelles, voire la mort.

6.2 Fault Condition

In the event of a fault condition, power cycle the tool to restore function.

6.3 Safety Checks

Inspect bake plate lid for the following defects:

- loose assemblies
- improper closure
- improper exhaust connection

6.4 Mechanical/Utilities Checklist

<u>Evaluate</u>	<u>Frequency</u>	<u>Detail</u>
Utility Gasses & Vacuum	Daily	Check all gas pressures and vacuum for ranges specified in tool manual.

Exhaust	Daily	Verify that the exhaust is functional with adequate flow.
Bake Plate Surface	Weekly	Buildup of material on the bake plate can cause vacuum errors. For minor build-up wipe the bake surface clean with isopropyl alcohol or acetone. For major build-up of material, utilize a glass slide held at a 45° angle to <i>gently</i> scrape the material away then wipe clean with isopropyl alcohol or acetone.
Lift Pin Height	Quarterly	If the three lift pins are not lifting the wafer programmed amount of distance from the bake plate surface, they may require calibration. See section 4.8 Tool Specific Settings – Apogee® Bake Plate for details.
Power	Bi-Annually	Verify that AC power is connected and of the proper voltage.

6.5 Cleaning

The Apogee® 300 Flange Bake Plate should be cleaned following daily use and only after the equipment has cooled to a safe thermal condition. The cabinet should be cleaned with isopropyl alcohol. When cleaning the hot plate surface, it is good practice to use the mildest solvent possible such as acetone or isopropyl alcohol. **Do not use caustic acids or bases.** For major build-up of material, utilize a glass slide held at a 45° angle to gently scrape the material away then wipe clean with isopropyl alcohol or acetone. Please visit the Cee® YouTube Channel for a [demonstration](#). If these methods are unsuccessful contact [Cee® Customer Support](#) for additional guidance.

Use only water-based cleaner on the labels on the rear of the machine. Use only isopropyl or water- based cleaner on the Power, Cee® logo, Caution ... Eye Protection, and the Cee® model/serial number labels. The display may be cleaned with glass cleaner, water, or isopropyl alcohol.

7 Table of Revisions

Doc Rev #	Author	Description of Change(s)	Reviewed/Approved By	Date
1.1	J. Adams	-Added Section 2.6 NRTL	B. Waterworth	7/11/2024